

ROKINON 4[®]

45mm F1.8 AF Instruction Manual for SONY E-Mount



Thank you for purchasing the Rokinon AF 45mm F1.8 Compact lens. It is a high performance prime autofocus optic designed specifically for SONY E-mount mirrorless cameras. Please note that supported functions may vary according to the camera model and that it will not mount to Sony A-mount cameras.

Advantages

- The 45mm focal length provides a natural appearance, approximating how we perceive a scene with our own eyes even more naturally than a 50mm lens. It is perfect for general purpose use and could live on your Sony at all times.
- It will provide optimal quality still images and video with both Sony Full Frame and APS-C image sensor cameras. For Sony APS-C camera users the lens is equivalent to approximately 67.5mm to provide an angle of view of a moderate telephoto.

- Seven elements in six groups, including two Aspherical and one Extra-low Dispersion plus Ultra Multi Coating, are utilized to minimize aberrations and increase sharpness for impressive image quality.

- The AF (autofocus) is optimized for quiet, fast, and precise focus detection with mirrorless cameras.

- The IF (Internal Focus) design prevents both changes length and front element rotation for easy use with polarizing and other filters where positioning must be maintained.













Cautions

To maintain your safety and prevent damage to the lens, please fully familiarize yourself with the following:

- Do not look directly at the sun through the lens as it may seriously impair your vision.
- Do not to apply excessive force when attaching the lens to the camera as it may cause damage to the lens or your camera.
- The lens is a precision optical product, so dropping or excessive impact may cause product failure.
- Attach or detach the lens only while the camera is turned off.
- Be careful not to touch or contaminate the gold contacts on the mount as it can adversely affect communication with the camera.
- Protect the lens from water, high humidity and excessive heat.
- Always store the lens with the lens cap on in a dry and well ventilated location out of direct sunlight. Direct sunlight passing through the lens could become concentrated enough to cause a fire.

- Avoid subjecting the lens to drastic temperature changes such as moving from a very cold outdoors location to a warm indoors location. This can cause moisture in the air to condense inside or on the outside of the lens and lead to failure or mold production. Before taking the lens indoors from a cold outdoors location, put the lens in a plastic bag or sealed camera bag and remove it only when the lens has warmed up to room temperature.

CAUTION

 <p>When mounting the lens make sure that it clicks in place otherwise it may detach and cause damage or injury.</p> 	 <p>Do not apply excessive force on the lens when it is attached to the camera. It may damage the lens and camera mount.</p> 	 <p>Ensure that the lens is operating properly by testing it on your camera before shooting an important event.</p> 
 <p>Do not modify or try to repair the lens as this will void the warranty.</p> 	 <p>Do not leave the lens in direct sunlight as this could cause a fire.</p> 	 <p>Do not look directly at the sun through a camera with a lens attached as it may damage your eyesight.</p> 

Cleaning

- It is extremely important before cleaning to dust off the lens surface using a lens blower or a soft brush to remove any foreign particles or grit that could scratch the lens.
- Using a clean microfiber lens cloth, gently wipe the lens in a circular motion from the center outwards towards the edges of the glass.

- If stubborn spots remain, put only one or two small drops of ethanol or reputable lens cleaner on the microfiber cloth and repeat the circular cleaning process. **DO NOT USE AN ORGANIC SOLVENT SUCH AS PAINT THINNER, ALCOHOL, OR BENZENE.**

Included Components

- Front Lens Cap
- Rear lens cap
- Lens Hood
- Semi Hard Case
- Instruction Manual
- Warranty Card

Attaching the Lens

- Remove the rear lens cap and the camera body cap.
- Align the white index mark (dot) on the lens barrel with the white index mark (dot) on the lens mount of the camera.
- Do not press the lens release button on the camera when mounting the lens.
- Insert the lens into the camera mount and rotate it clockwise until it "clicks" and locks in place. Do not insert the lens at an angle.
- Remove the front lens cap when you are ready to shoot.

Detaching the Lens

- Attach the front lens cap.
- While holding down the lens release button on the camera body, rotate the lens counterclockwise until it stops and separate the lens from the body.
- Attach the rear lens cap.

Parts

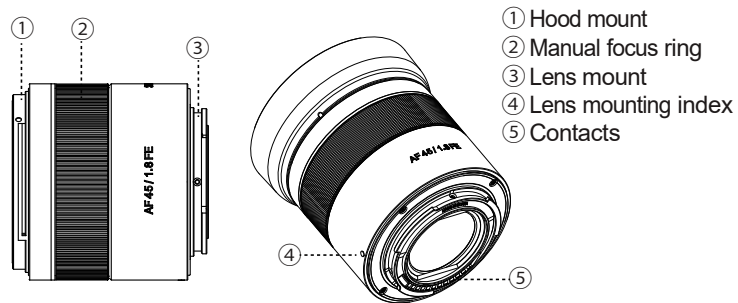

Focusing

Sony mirrorless interchangeable lens cameras offer various methods of focusing. For detailed information regarding the available focus mode settings for your particular model, refer to the instruction manual of your camera. Supported modes and functions may vary.

- AF-S (Single-Shot AF): Autofocus operates when the shutter button is pressed halfway down. Once the subject is in focus, the focus is locked. It is suitable for shooting motionless subjects such as landscapes or snapshots.

- AF-C (Continuous AF): Autofocus continues to adjust the focus while the shutter button is pressed and held halfway down. It is suitable for shooting moving subjects such as sports.

- AF-A (Automatic AF): When the shutter button is pressed halfway down, the camera automatically recognizes whether the subject is moving or not, and switches the AF mode between AF-S and AF-C accordingly. Use this mode to shoot various subjects at the same time or to avoid switching the AF mode manually.

- DMF (Direct Manual Focus): Allows you to use manual focus and auto focus in combination. Press the shutter button halfway down to focus automatically. Keep the shutter button halfway down and rotate the focusing ring on the lens to fine focus.

- MF (Manual Focus): Allows you instead of the camera to adjust the focus by rotating the focusing ring on the lens. MF is effective when autofocus does not work well such as in macro shooting.

Lens Hood

The supplied hood is designed specifically for the Rokinin AF 45mm F1.8 Compact lens for optimum effectiveness. It should be used at all times to help prevent contrast reducing flare, provide better contrast and for added protection.

- To mount the hood, align the white index mark (dot) of the hood with the white hood index mark (dot) of the lens and rotate the hood clockwise until you hear and feel it click in place.

- To remove the hood, grasp it firmly and turn counter-clockwise.

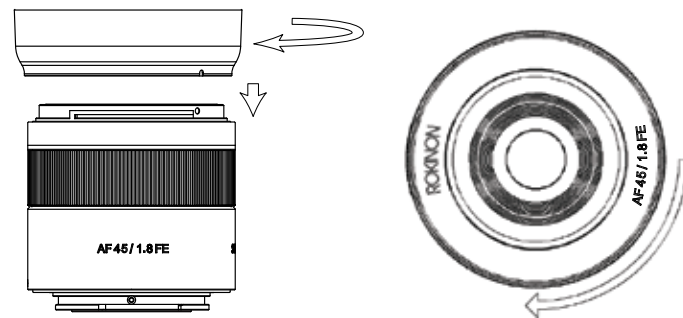

ROKINON Lens Station

The Rokinin Lens Station model IOLS-E is an optionally available accessory designed exclusively for Rokinin AF Sony E-Mount lenses.

It allows you to connect Rokinin AF Sony E-Mount lenses to your computer to update firmware, calibrate, and customize focus, and aperture parameters. It utilizes Lens Manager Software which is available for free for Windows or Mac at: rokinon.com/downloads/lens-station-software.

Product Specifications

Model name	IO45AF-E	
Aperture range	F1.8 ~ 22	
Angle of View	Full Frame	52.31°
	APS-C	35.31°
Optical construction	7 elements in 6 groups 2 Aspherical 1 Extra Low Dispersion	
Minimum focusing distance	1.48 ft (0.45m)	
Maximum shooting magnification	X 0.12	
Filter size	49mm	
Number of aperture blades	9	
Maximum diameter X length	2.43" x 2.21" (61.8mm x 56.1mm)	
Weight	5.71oz (162g)	

- The minimum focus is the distance from the image sensor to the object.
- The product specifications and exterior are subject to change without notice.

Contact

support@rokinon.com
Phone: 212.947.7100
Toll Free: 800.441.1100

rokinon.com
facebook.com/rokinonlenses
instagram.com/rokinon

ROKINON® is owned and operated solely by Elite Brands Inc.
©2019 Elite Brands Inc., New York, NY 10005

Notes